

CHALWYN

DIESEL PROTECTION SYSTEMS

**PVX-Series Diesel Engine Air Shut Down Valves
(Pneumatically Actuated)**

SELECTION, APPLICATION AND MAINTENANCE

Valve Numbers	
PVX-300	PVX-301
PVX-500	PVX-501
PVX-800	PVX-801

DESCRIPTION

Pneumatically operated diesel engine air intake closure valves based on the standard Chalwyn slimfit 3", 5" and 8" butterfly valves with variants for both hazardous and non-hazardous areas. Available in basic flange mounted form or supplied fitted with hose adaptors or an integral flame trap housing. Body and disc manufactured in corrosion resistant hard anodised aluminium with PTFE coating.

Typical PVX Valve Arrangement

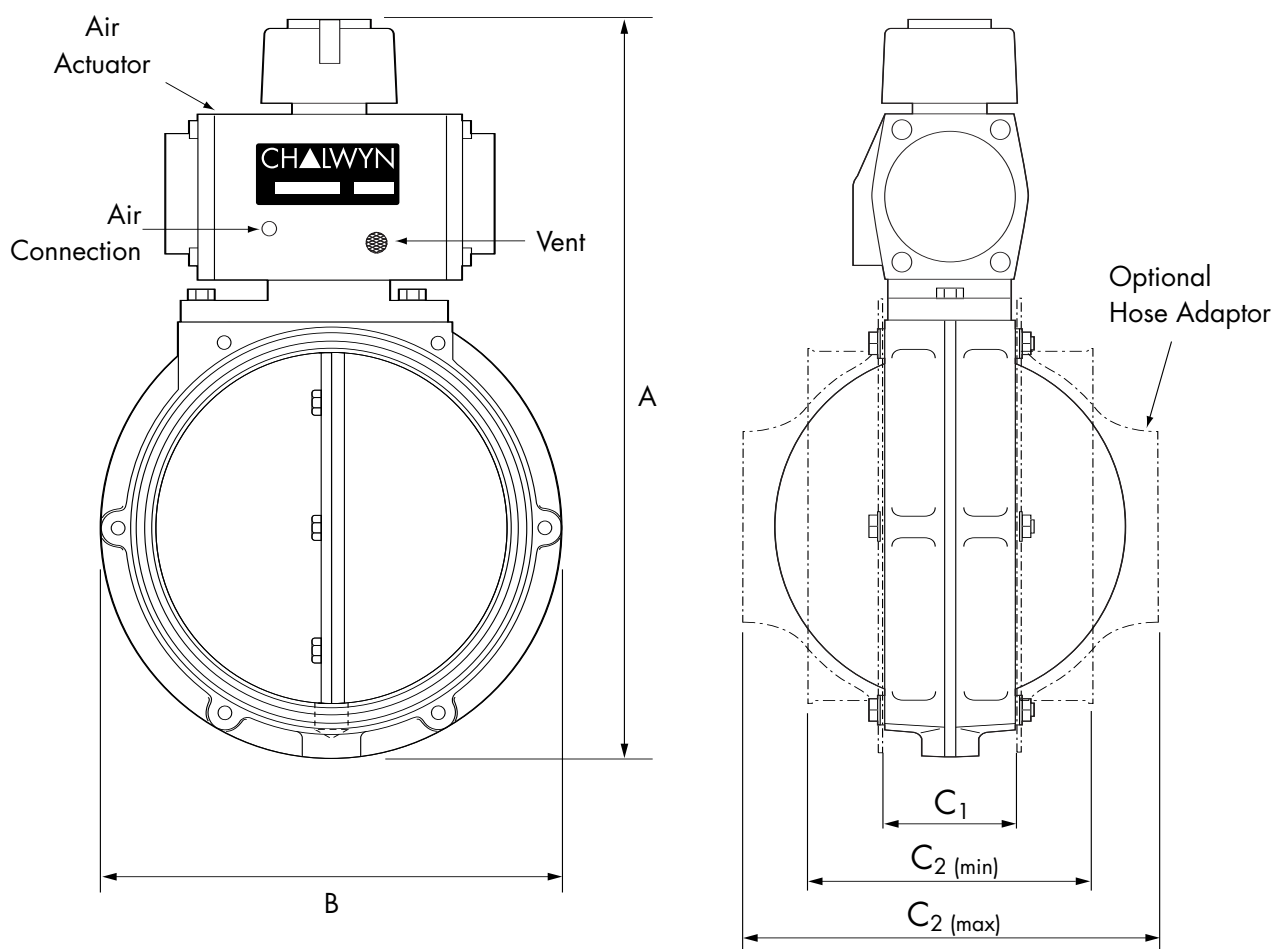

Main Dimensions (mm)

Valve Type	Nominal Bore Diameter	A mm	B mm	C ₁ mm	C ₂ minimum & maximum
PVX-300	76 (3")	208.0	111.5	37.5	82.5 to 112.5
PVX-301					
PVX-500	127 (5")	257.0	167.0	45.5	102.0 to 157.5
PVX-501					
PVX-800	203 (8")	354.5	257.0	56.0	136.5 to 185.5
PVX-801					

SELECTION

Determine the size and position of the PVX valve to be installed. Within the various constraints imposed in the application the valve should be as generously sized as possible. A pneumatic supply must be available to operate this valve type. PVX-300, PVX-500 and PVX-800 valves open on the application of air pressure. PVX-301, PVX-501 and PVX-801 close on the application of air pressure. The 'fail safe' mode of operation of the PVX-300, PVX-500 and PVX-800 models makes them suitable for use in zone 1 hazardous areas.

Ideally if hose adaptors or an integral intake flame trap housing is to be used, these should be identified and ordered from Chalwyn at the same time as the basic PVX valve.

Hose Adaptor Options

76mm (3") Bore Valves	
Adaptor Part Number	To Suit Hose Bore mm (inches)
HAX-301	51 (2)
HAX-302	54 (2 1/8)
HAX-303	57 (2 1/4)
HAX-304	60 (2 3/8)
HAX-305	63.5 (2 1/2)
HAX-306	67 (2 5/8)
HAX-307	70 (2 3/4)
HAX-308	73 (2 7/8)
HAX-309	76 (3)
HAX-314	89 (3 1/2)
HAX-319	102 (4)

203mm (8") Bore Valves	
Adaptor Part Number	To Suit Hose Bore mm (inches)
HAX-807	178 (7)
HAX-808	203 (8)

127mm (5") Bore Valves	
Adaptor Part Number	To Suit Hose Bore mm (inches)
HAX-501	89 (3 1/2)
HAX-502	92 (3 5/8)
HAX-503	95 (3 3/4)
HAX-504	98 (3 7/8)
HAX-505	102 (4)
HAX-506	105 (4 1/8)
HAX-507	108 (4 1/4)
HAX-508	111 (4 3/8)
HAX-509	114 (4 1/2)
HAX-510	117.5 (4 5/8)
HAX-511	121 (4 3/4)
HAX-512	124 (4 7/8)
HAX-513	127 (5)
HAX-518	140 (5 1/2)
HAX-523	152 (6)

Notes

Alternative types of air actuated valves are available from Chalwyn - see brochures CE231, CE236 and CE237.

If automatic diesel fuel shut down is required in combination with air intake shut down a Chalwyn FSX-100 fuel shut down valve should also be specified (brochure CE226).

INSTALLATION

- 1.** In the case of a naturally aspirated engine the Chalwyn PVX shut down valve should generally be fitted as close to the engine air intake manifold as possible. If an air intake flame trap is also fitted, the PVX valve must be installed upstream (air cleaner side) of the flame trap.
- 2.** To avoid excessively high temperatures at the PVX valve when fitted to a turbocharged engine, it is recommended the valve is fitted either upstream of the turbocharger or downstream of the inter-cooler (if fitted). Again, if an air intake flametrap is also fitted, the valve must be installed upstream of the flametrap.
- 3.** Where more than one PVX valve is fitted to an engine, as in the case of an engine with multiple intake pipes, a common pneumatic supply to the valves should be used to ensure that all valves close simultaneously. A balance pipe arrangement should also be incorporated to connect the separate intake pipes together downstream (engine side) of the shut down valves. Typically balance pipe diameters should be about 30% of the diameter of the intake pipes.
- 4.** The PVX valve may be installed either horizontally or vertically.
- 5.** If hose adaptors are used, the mating hose should be of a reinforced type, provide adequate support for the valve and prevent excessive vibration. If necessary, additional support brackets mounted from the engine should be considered.
- 6.** Particular care must be taken to ensure the integrity of the intake pipework between the Chalwyn valve and intake manifold. Ideally metal pipework should be used and any gaps kept as short as possible, (taking into account any relative movement) and closed by reinforced hose. The possibility of a hose collapse on closure of the shut down valve must be avoided.
- 7.** Any engine crankcase breather connections into the intake system between the PVX valve and engine, or any internal crankcase breather arrangement venting directly into the engine intake ports must be sealed and replaced by an external breather system venting either to atmosphere or to the intake system upstream of the shut down valve. External breather system kits for various engine types are available from Chalwyn.

OPERATION

PVX-300, PVX-500 and PVX-800

Prior to engine start, air pressure must be applied to these PVX valves to open to the engine run position. (Note, the external yellow indicator on the valve shows the position of the valve disc). Air pressure must be maintained between 4 and 8 bar to hold the intake valve fully open whilst the engine runs. To carry out an emergency engine stop by closing the air intake valve, close down the air supply and vent the supply line. The valve will fully close once the air supply pressure at the valve falls below 2 bar.

PVX-301, PVX-501 and PVX-801

With no air pressure applied to these PVX valves they will be fully open and the engine may be run. To carry out an emergency stop apply an air pressure of 4 to 8 bar to close the intake shut down valve. The supply pressure must be vented before attempting to re-start the engine.

NOTE: The pneumatic supply to the valve must be clean and dry.

MAINTENANCE

WEEKLY:

Exercise the valve by applying and venting the control air supply pressure. Check by observing the external indicator that the valve is freely moving between the open and closed positions.

MONTHLY:

Check that the fasteners locating the PVX valve and any associated intake system or support bracket fasteners are securely tightened.

Check that any flexible hoses in the engine intake system between the PVX valve and engine are free from damage and suitable for further service.

Check that the air supply pipe to the PVX valve is properly supported, free from damage and the pipe fittings are tight.

Run engine, preferably at low idle. Vent (or supply as appropriate) the control air pressure to the PVX valve and check that the engine stops within a few seconds. If not, check the engine air intake system for leaks. Should this not solve the problem remove the intake valve and return to Chalwyn for further investigation.

CHALWYN LIMITED

Chalwyn Industrial Estate, Parkstone, Poole, Dorset BH12 4PF ENGLAND

Tel: +44(0)1202 715800 Fax: +44(0)1202 715600

www.chalwyn.co.uk

CE218 - 7



CHALWYN LIMITED RESERVE THE RIGHT TO UPDATE THIS PRODUCT SPECIFICATION WITHOUT PRIOR NOTICE.